

AUTOMATIC TRANSFER SWITCHES

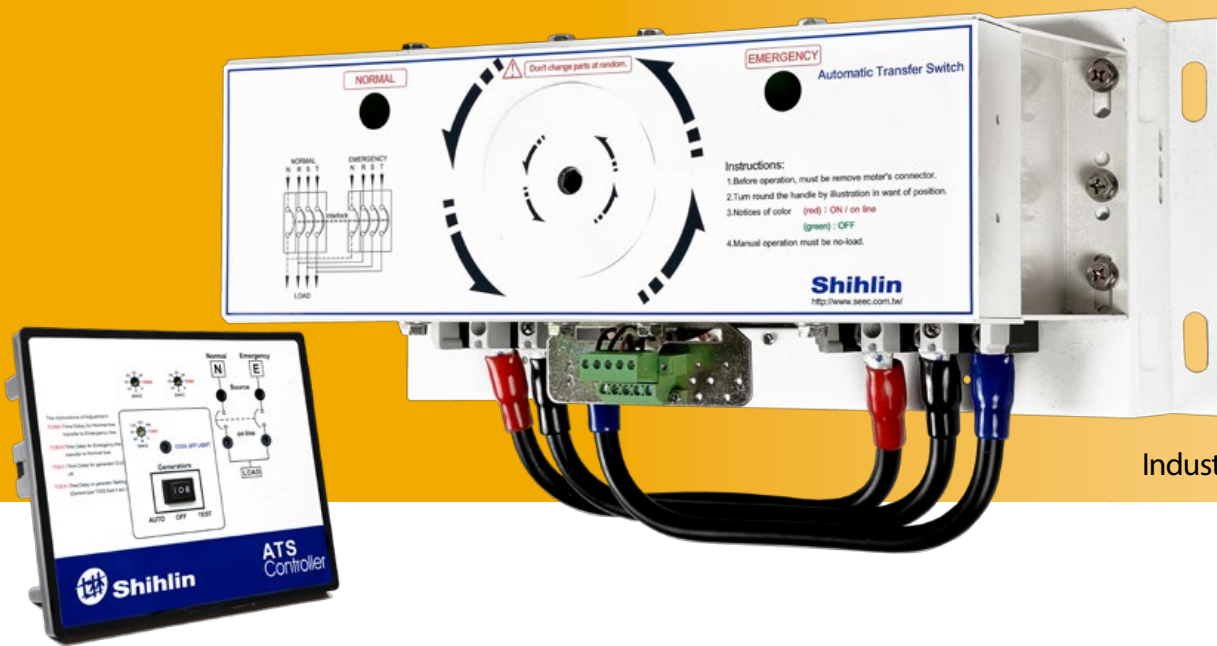

Industrial use

Index

A. ATS Introduction	P2
B. Specification	P2
Instruction Manual	P3
The Main Structure Analysis	P4
ATS Controller	P5
Control Unit Circuit Diagram	P6
Wiring Diagram	P7
Dimensions	P8
Q&A and Maintenance	P10

A. ATS Introduction

1. Functions and Features:

- Main function is in the event that power is lost from the normal source; the transfer switch transfers the load to the standby source. Once normal power is restored, the load was transferred back to the normal power source.
- The mechanical interlock: To ensure two power sources cannot both switch on concurrently.
- The transmission gear: In order to avoid switching errors, two power sources will be switched off first, then one can be switched on.
- Adding lock for insulating operation handle (optional): To prevent error operating from unauthorized personnel.
- Load bus bar (400A above): Forging with pure copper and covering with insulating resin, the dielectric withstanding voltage is up to 1000V.
- Optional function:
 - Phase failure detection
 - Auxiliary contact

2. Standard Equipment:

- Two Shihlin's MCCBs (with overload and short-circuit protection)
- Basic transfer switch
- Electrical and mechanical interlock
- Simple manual handle
- Panel controller (Three adjustable delay timers and one fixed delay timers)
- Power failure simulation test device

3. Optional Accessories:

- Over & under voltage protection
- Insulating operating handle with lock
- Phase failure detector
- 440V above power transformer for controller
- Enclosure



(For voltage: 220V/380V)

B. Specification

Type	Pole	Rated current In (A)	Rated Breaking Capacity Sym r.m.s. (kA) IEC 60947-2 AC (Icu)	
			220V	380V
BS100SN	2P, 3P, 4P	10, 15, 20, 30, 40, 50, 60, 75,	25	15
BS100HN	2P, 3P, 4P	100.	50	30
BS250SN	2P, 3P, 4P	125, 150, 175, 200, 225, 250.	50	30
BS400SN	2P, 3P, 4P	250, 300, 350, 400.	50	35
BS400HN	2P, 3P, 4P		85	50
BS630SN	3P, 4P	500, 600, 630.	50	35
BS630HN	3P, 4P		85	50
BS800SN	3P, 4P	700, 800.	85	50
BS1000HS	3P	1000.	130	100
BS1200HS	3P	1200.	130	100
BS1600HS	3P	1400, 1600.	130	100

Note: 1. Rated breaking capacity (kA) IEC 60947-2

2. Please contact us for higher breaking capacity type.

3. BS225SN rated current 250A is optional order.

Instruction Manual

Shihlin Electric ATS is manufactured under strict quality control, they are in full compliance with the IEC standards, MCCB is qualified by BSMI R.O.C., controller receives EMC test certification with the capability of anti-surge lightning and anti-noise; quality products with high performance and reliability, perfect satisfaction is guaranteed to our customers.

1. ATS should be installed in the access control of the electrical room, in order to avoid any error operation and accidents, non-electrical maintenance and unauthorized personnels are not allowed close to it.

2. Operation environment condition. The following locations should be avoided:

1. Humid
2. High temperature
3. Vibration-prone
4. Oil and gas
5. Dusty

3. Attention before energizing:

1. Please turn off all the switches of ATS.
2. Please check the wiring of power line.
3. Please remove anything which is not necessary to ATS.
4. Please check whether there are short circuit and grounding on the normal power source, emergency power source and load power source.
5. Please check whether the terminal blocks with locking on the normal power source, emergency power source and load power source.
6. Please do not use megohmmeter(high voltage insulation device) to measure due to all control circuit as delay timer and voltage protection are electronic products.

4. Attention during operation:

1. Please do not overhaul and touch any terminal.
2. Please do not rotate the manual operating handle except the special situations.
3. Please do not change any switch except the specific needs.

5. Manual operation method:

Please use below method to operate when the ATS can't transfer automatically after the main switch tripped:

Please remove the motor power wire quickly before ATS operate automatically, and switch the position you need manually by the counter-clockwise direction, there are on and off indicator on ATS.

6. Please read this instruction manual before operation. The disassembly by non-original manufacturer is against the warranty and prohibited.

The Main Structure Analysis

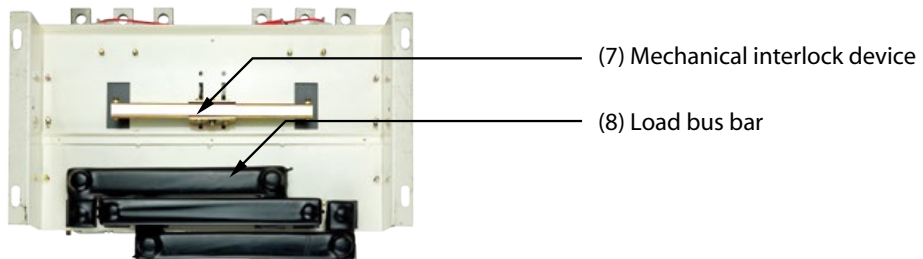
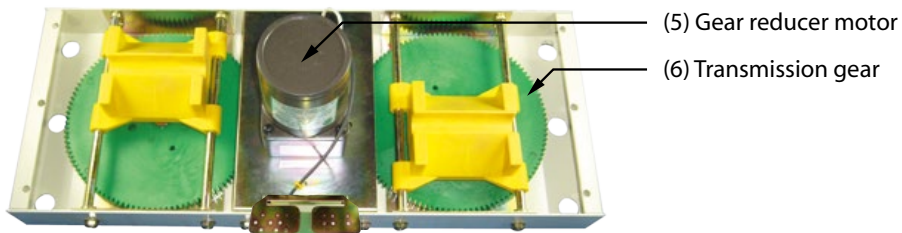
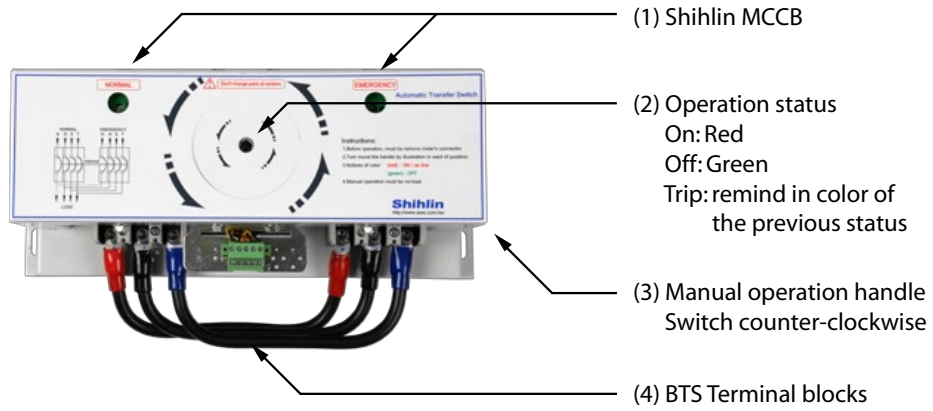

ATS Controller

1. Features

- a. EMC test certification with the capability of anti-surge lightning and anti-noise.
- b. Signal is readable: Clear the status of power source.
- c. Self-test function: It can test the circuit operation procedures and processes without power outage.
- d. Optional accessories: Over & under voltage protection, phase failure detector can be assembled without dismantling the body.

2. Functions

a. TDEN (Time Delay Emergency to Normal)

Transfer time delay adjustment: 0~30 second

b. TDNE (Time Delay Normal to Emergency)

Transfer time delay adjustment: 0~30 second

c. TDES (Time Delay Engine Start)

Engine start time delay: Built-in fixed 3 second

d. TDEC (Time Delay Engine Cool-down)

Engine off time delay adjustment: 0~180 second



Input control voltage: 220V (standard)
Panel cut-out: 194.5mm(W) × 164mm(H)

3. TEST push-button on lateral panel

Pushing TEST button can let generator run when it is in a supposed case of power outage.
We can know the function of ATS is normal or not.

4. Three position switch

- a. Test: Generator remote start testing.
- b. Off: Transfer function "OFF"
- c. Auto: Transfer function: ON

5. Panel LED indicators

Current power source: Emergency / Normal

6. Auxiliary contacts (Optional)

Normal power source relay (NR) 2NO 2NC

Emergency power source relay (ER) 2NO 2NC

7. Phase failure and reverse phase relay (PR) (Optional)

Phase sequence and phase failure of three phase to prevent motor running by reverse phase.

8. Control circuit fuse (F)

9. Over & under voltage protection (Optional)

Control Unit Circuit Diagram

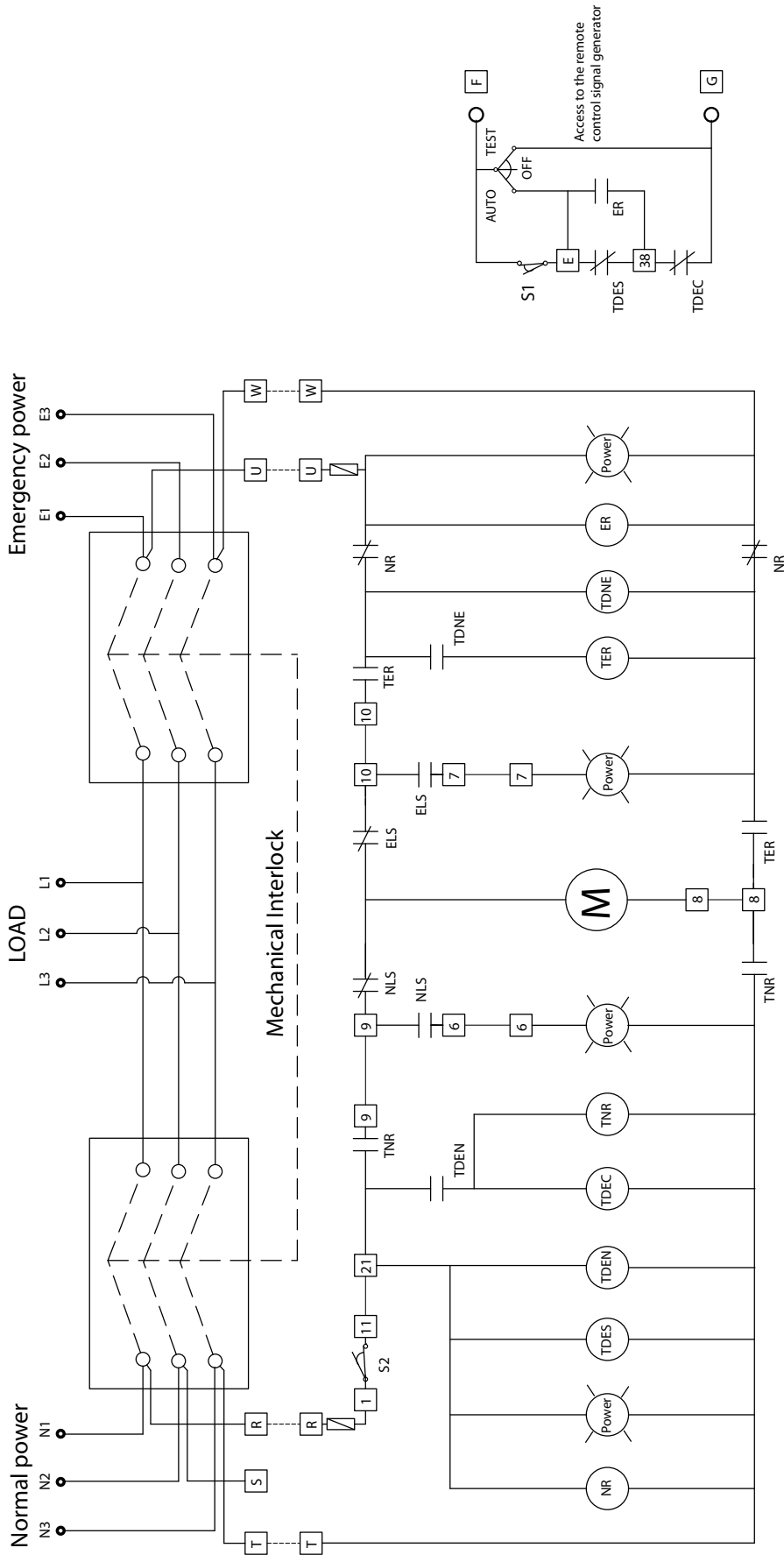

Notes:

- (1). S1 Generator auto remote control/Test function
- (2). S2 Normal power outage simulation test
- (3). M Operation deceleration motor
- (4). Please use transformer if the control voltage is not 220V.

Code Description:

- TNR : TER ` ER ` NR: Power relay
- NLS: Normal power source auxiliary contact
- ELS: Emergency power source auxiliary contact
- TDEN: Time delay emergency to normal
- TDNE: Time delay normal to emergency
- TDEC: Time delay engine cool down
- TDES: Time delay engine start

Wiring Diagram

ATS Control Wiring Diagram

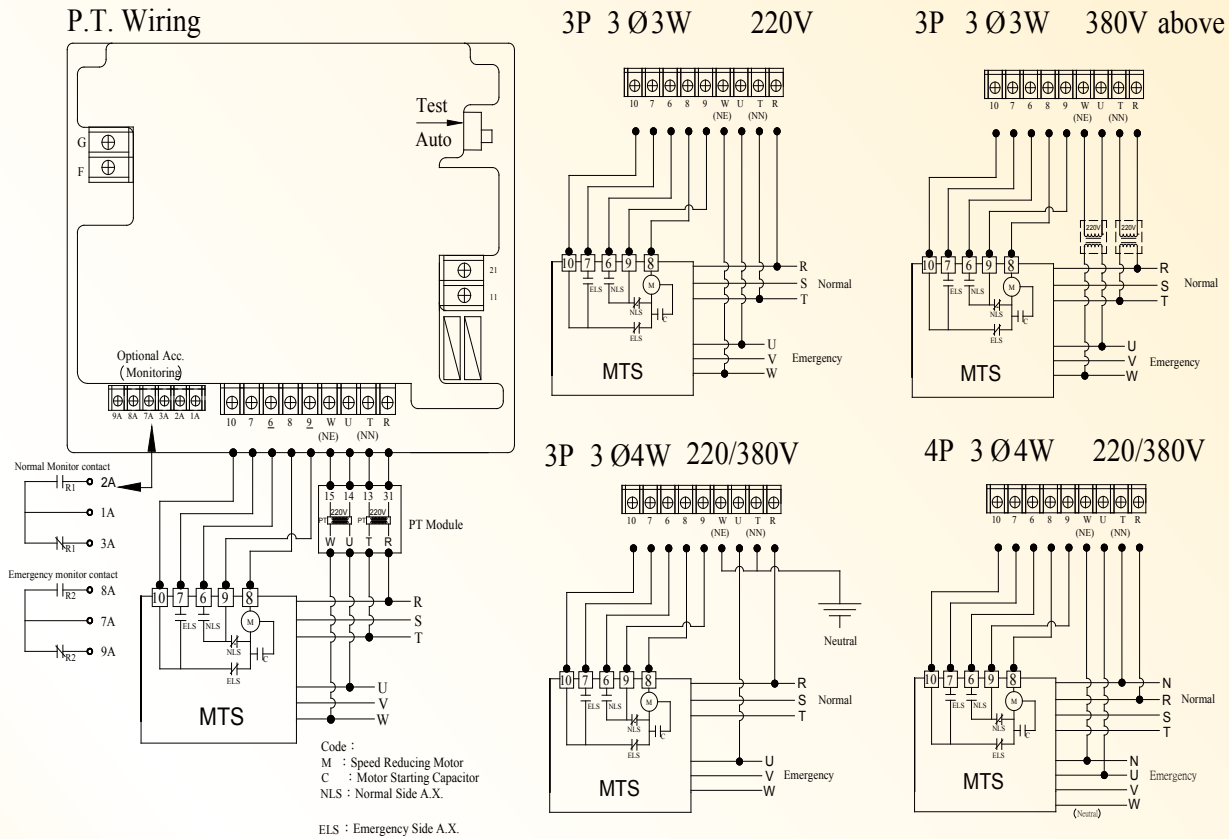

Wiring Connection

System	Connection			
	Normal	Emergency	Remark	
3P	3 φ 3W, 220V	R, T	U, W	
3P	3 φ 4W, 220/380V	R	U	Neutral Wiring - T, W
	3 φ 3W, 380V and above	R, T	U, W	Step down the power to 220V by P.T
2P	3 φ 4W, 220/380V	R, NN	U, NE	
	3 φ 4W, 120/208V	R, T	U, W	

Dimensions (mm)

1. BTS

3P

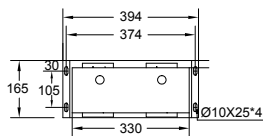

Compatible with:
BS100CN / SN / HN

4P

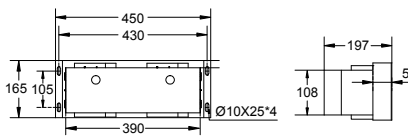

Compatible with:
BS100CN / SN / HN

3P-225AF

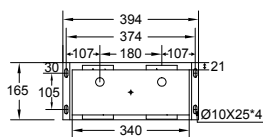

Compatible with:
BS225CN \ BS225SN

4P-225AF

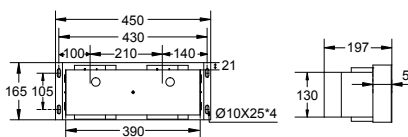

Compatible with:
BS225CN \ BS225SN

3P-400AF

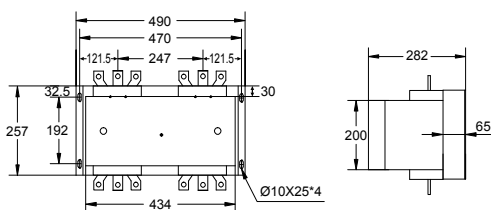

Compatible with:
BS400CN \ BS400SN \ BS400HN

4P-400AF

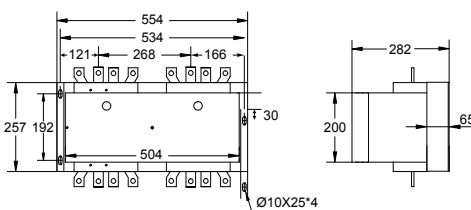

Compatible with:
BS400CN \ BS400SN \ BS400HN

3P-600AF \ 3P-800AF

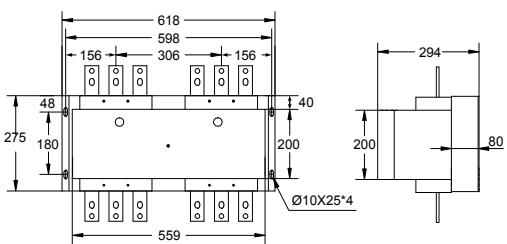

Compatible with:
BS600CN \ BS600SN \ BS600HN
BS800CN \ BS800SN

4P-600AF \ 4P-800AF

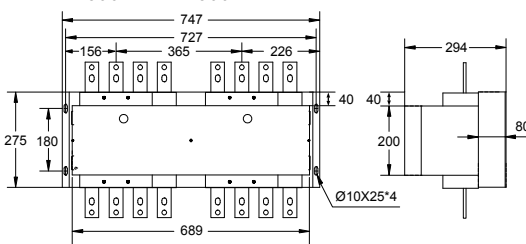

Compatible with:
BS600CN \ BS600SN \ BS600HN \ BS800CN \ BS800SN

3P-1200AF

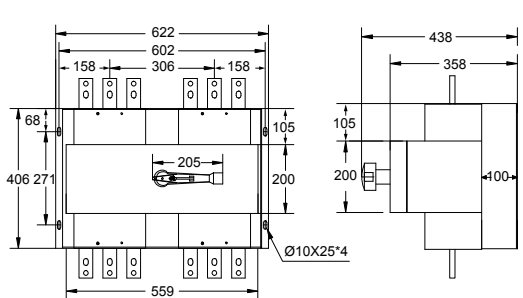

Compatible with:
BS1000HS \ BS1200HS

3P-1600AF

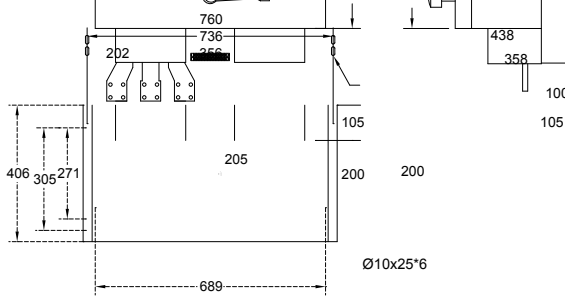

Compatible with:
BS1600HS

2. Controller

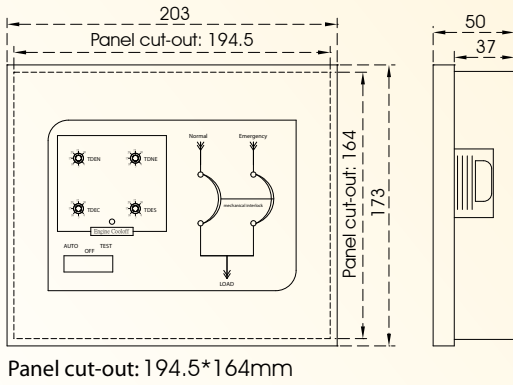

3. Over & under voltage protection

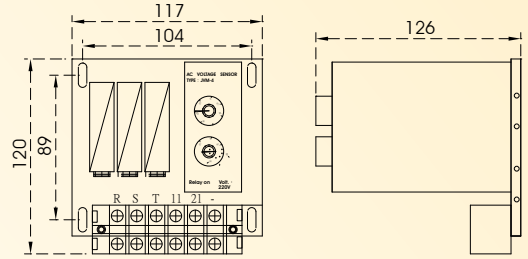

4. Transformer

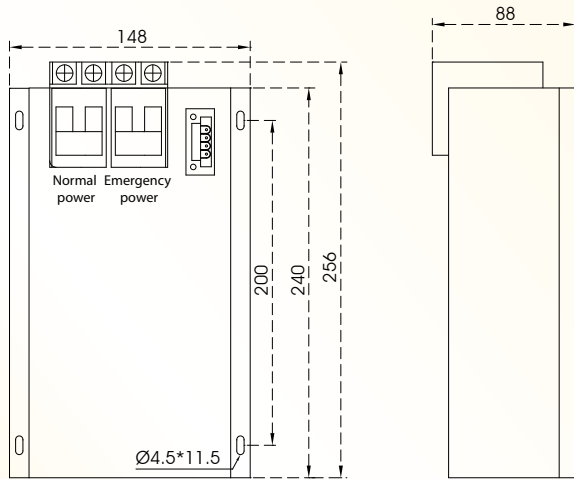

5. Phase failure protection

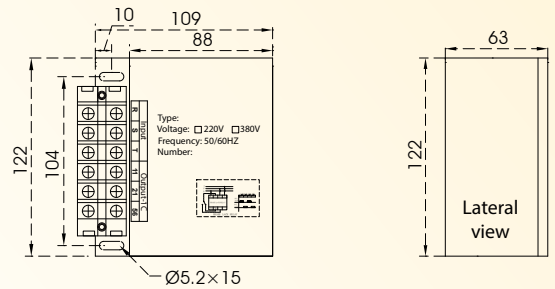

6. Enclosure

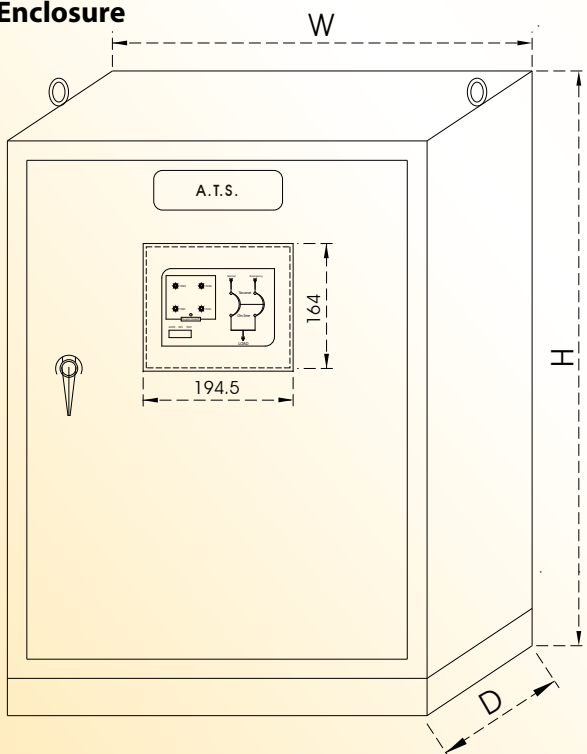

3P

Type	Dimension	W	H	D
BS 100AF, BS225AF		455	485	330
BS400AF		610	750	400
BS600AF, BS800AF		760	1100	450
BS 1000AF		1000	1500	450

4P

Type	Dimension	W	H	D
BS 100AF, BS225AF		511	485	330
BS400AF		680	750	400
BS600AF, BS800AF		890	1100	450

Description:

1. Lift lugs are attached on the top of enclosure
2. Exterior handle with lock
3. Enclosure color: 5Y7-1
4. Thickness
 - a. 250AF below: 1.6mm
 - b. 400AF above: 2.0mm

Q&A and Maintenance Description

1. Why the generator can not start when the normal power source is unavailable ?

- A. Switch to "Test" position on controller
- B. Causes of generator can not start:
 - a. Generator remote signal wire is not connected.
 - b. Generator is not set on "Auto" .
 - c. Remote single wire is too thin (3.5mm² and up) or distance is too far.
- C. Switch back to "Auto" on controller when above conditions are solved.

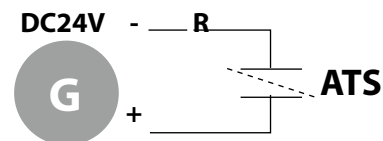

2. Why does ATS not switch the power source when the normal power source is unavailable and generator is running ?

Please check if emergency power source status LED flashes.

If No:

- a. The generator output doesn't reach AC220V, Please check the voltage on UW.
- b. Neutral is not connected.
- c. Fuse burnout.

If Yes:

- a. Please check if there is AC220V on contact (8) and (10)
 - Yes, Check if the capacitor wire on motor is properly wired.
 - No, please contact technique personnel.

Generator start function



3. Why does ATS not switch back from emergency when the normal power is back on?

Please check if normal power source status LED flashes.

If No:

- a. The normal power output doesn't reach AC220V, Please check the voltage on (R) and (T).
- b. Neutral is not connected.
- c. Fuse burnout.
- d. Please switch to "Auto" on the back of the controller.
- e. Check if the jump on contact (11) and (21) are loose.

If Yes:

- a. Please check if there is AC220V on contact (R) and (T)
 - Yes, please contact technique personnel.

LED indicator of emergency power source status

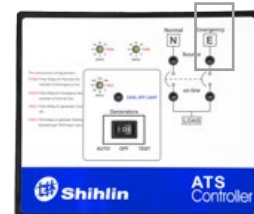

LED indicator of normal power source status



4. Why the generator can not stop running after TDEC time when the standby power source backed to the normal power source ?

Please check if TDEC status LED flashes.

If Yes: (Generator is still running)

- a. Check if the generator equips its own delay timer.
- b. Other ATS is using the same generator.
- c. Check if the generator is set on Auto mode.

If No: Please contact technique personnel.

LED indicator of generator cool off status

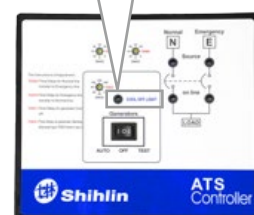

5. Why is gear reducer motor keeping switching?

- A. Circuit breaker can't reset from trip position
- B. Mechanical interlock fail
- C. Disconnect motor power (8)

SHIHLIN ELECTRIC & ENGINEERING

MOTOR CONTROL (CONTACTOR/ MS/ MMS), CIRCUIT BREAKER (MCCB/ ELCB/ EMCCB/ MCB), AIR CIRCUIT BREAKER, AUTOMATIC TRANSFER SWITCHES (Panel Board Type/ Residential Unit Use), SURGE PROTECTIVE DEVICE, LOW VOLTAGE POWER CAPACITORS, SMART METER, INVERTER



Breaker & switchgears overseas sales dept.

3F, No.9, Sec. 1, Chang-an E. Rd., Zhongshan Dist., Taipei City 10441, Taiwan

T. +886-2-2541-9822 F. +886-2-2581-2665

e-mail. b.export@seec.com.tw

<http://circuit-breaker.seec.com.tw>

Headquarters

16F, No.88, Sec. 6, Zhongshan N. Rd., Shilin Dist., Taipei City 11155, Taiwan

T. +886-2-2834-2662 F. +886-2-2836-6187

<http://www.seec.com.tw>

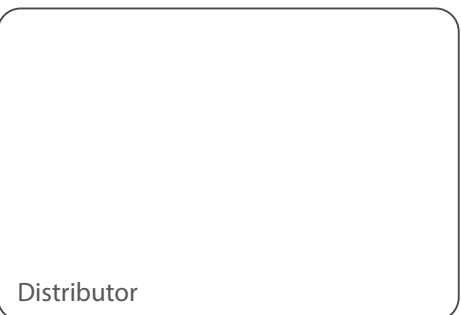

Distributor

B150916E.ATS-MCCB.OB